

# ROM-8720

## NXP Layerscape 1046A Cortex-A72 COM Express Type 7 核心模块



- NXP Arm Cortex-A72 COM Express Type 7 标准
- 板载 Micro SD 插槽 和 EMMC 16GB
- 1 x SO-DIMM 支持 ECC 和 Non-ECC DDR4
- 10GBase-KR x2, GbE up to 4, PCIe 1x x 3, USB 3.0 x 3, USB 2.0 x 3, SATA V3.0 x 1
- 4 wires UART x 2, SPI x 1, GPIO x 8, I2C
- DPAA (高性能数据通道加速结构) SDK
- 低功耗设计
- 支持 Linux BSP



### 产品介绍



研华 ROM-8720 COM Express Type 7 紧凑型核心板内置 NXP LS1046A SoC，其中包括四个 Arm Cortex-A72 内核，用于边缘网络和边缘防火墙，两个 10Gbps-KR 和高达 4Gbps 的网络通信。3 个 PCIe、3 个 USB 3.2 Gen1 和 3 个 USB 2.0 用于嵌入式接口扩展。2 个 UART，1 个 SPI 和 8 个 GPIO 用于嵌入式设备控制。

ROM-8720 与研华 SOM-DB5920 评估载板配套使用，可加快终端产品外设集成速度，缩短产品上市时间。用于载板开发的参考原理图和布局清单文档将与带有 DPAA (数据路径架构加速) SDK 的 Linux BSP (用于队列/缓冲区/帧管理器和 SEC 加密)、测试实用程序、硬件设计实用程序和参考驱动程序一起提供。

### 规格

Form Factor		COM Express Type 7 Compact
Processor System	CPU	NXP Arm® Cortex®-v8 A72 LS1046A quad 1.6GHz
	Technology	LPDDR4 2133 MT/s
Memory	Capacity	1 SO-DIMM supports ECC and Non-ECC, up to 16GB
	Flash	16 GB eMMC/Micro SD socket for O.S. and 32 MB QSPI NOR Flash for board information
Graphics	LVDS/MIPI DSI	-
	HDMI	-
	Parallel RGB	-
	VGA	-
	Graphics Engine	-
	H/W Video Codec	-
Ethernet	Chipset	NXP LS1046A integrated XFI, RGMII, SGMII
	Speed	Up to 10Gbps
RTC	RTC	Yes
WatchDog Timer		256 Level timer interval, from 0.5~128 secs
Security		SFP (Security Fuse Processor)
I/O	PCIe	1x Gen3.0 x3 / 1x Gen 2.0 x3
	SATA	SATA V3.0 x1 (only ROM-8720WQ-RA1E supports)
	USB	USB 3.2 Gen1 x3, USB 2.0 x3
	Audio	-
	SPDIF	-
	SDIO	-
	Serial Port	2-wire UART x2
	SPI	1 (shared w/ Micro SD)
	CAN	-
	GPIO	8
	I²C	1
	Camera Input	-
	System Bus	-
Touch	-	
Keypad	-	
Power	Power Supply Voltage	12V
	Power Consumption	12.71 Watt
Environment	Operating Temperature	-40 ~ 70 °C
	Operating Humidity	5 ~ 95% relative humidity, non-condensing
Mechanical	Dimensions (W x D)	95 x 95 mm
Operation System		Ubuntu
Certifications		CE/FCC Class B

## 架构图

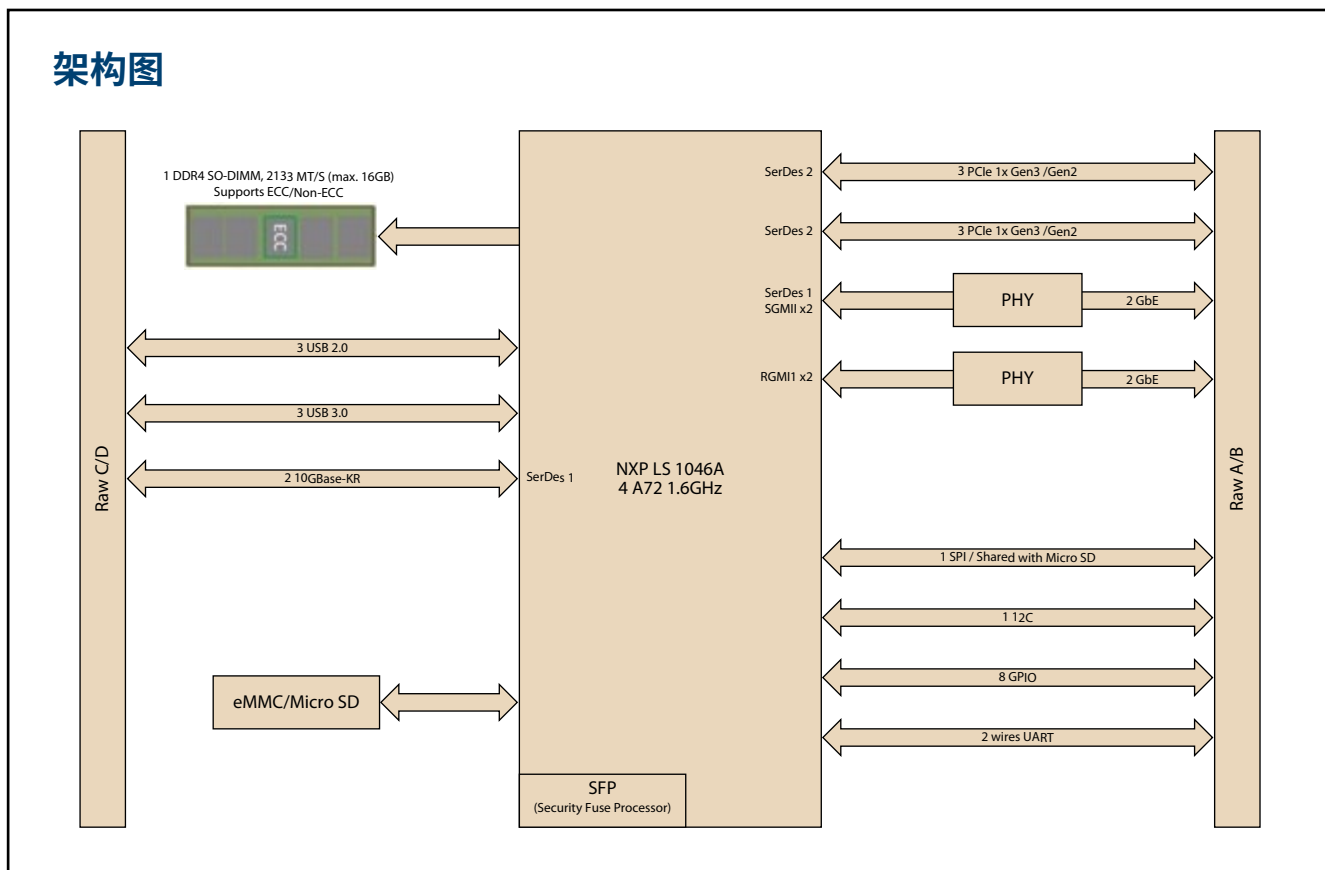

## 订货信息

Part No.	CPU	Memory	Flash Memory	UART	LAN	USB 3.0	USB 2.0	SO-DIMM	PCIe	SD	SATA	I <sup>2</sup> C	SPI	Size	Power input	Operating Temperature
ROM-8720WQ-R0A1E	LS1046A	SO-DIMM	16 GB	2	10 Gbps-KR x2 & up to GbE x4	3	3	4GB	3 Gen3.0	1	-	1	1	95 x 95 mm	12V	-40 ~ 70 °C
ROM-8720WQ-R1A1E	LS1046A	SO-DIMM	16 GB	2	10Gbps-KR x2 & up to GbE x4	3	3	4GB	3 Gen2.0	1	1	1	1	95 x 95 mm	12V	-40 ~ 70 °C

## 开发底板

Part No.	Description
SOM-DB5920-00A1	Development board for COM Express Type7 Module series

## 可选配件

Part No.	Description
EWM-W168H01E	RTL8822BE-CG 802.11 a/b/g/n/ac WIFI & Bluetooth 4.2 mini-PCIe
1750008717-01	Dipole Ant. D.B 2.4/5G WIFI 3dBi SMA/M-R BLK
1750008800-01	Cable Ant.SMA/F-R-BH MFH4/113 BLK L100
EWM-C117FL06E*	LTE 4G,3G WCDMA/DC-HSPA+, 2G module, MPCII-L280H
1750007990-01	Antenna 4G/LTE full band L=11 cm 50 Ohm
1750006009	Antenna Cable SMA (F) to MHF 1.32 25cm
SQR-SD4M4G2K6SNEFB	260pin SODIMM DDR4 2666 4GB 1.2v 512x8 (-20-85 °C)
SQR-SD4M8G2K6SNBCB	260pin SODIMM DDR4 2666 8GB 1.2v 1Gx8 (-20-85 °C)
SQR-SD4I4G2K6SEEFB	260pin SODIMM ECC DDR4 2666 4GB 1.2v 512x8 (-40-85 °C)
SQR-SD4I8G2K6SEBCB	260pin SODIMM ECC DDR4 2666 8GB 1.2v 1Gx8 (-40-85 °C)
1970005494T001	HD R2 NXP.-LS1046A 24W 95x95x11mm SC Mobile
1970004870T011	CL R3 NXP.-LS1046A 24W 95x95x33.2mm SC Mobile

\*Please contact us for suggesting suitable cellular module for your region.